

DESCRIPTION

The UCM-81/82 modems are a series of general-purpose industrial modems, which can be used for data communication through Public Switched Telephone Networks (PSTN). The modems can operate in 2-wire, full-duplex, asynchronous modes at line rates up to 56 Kbps and can perform complete handshake and data rate negotiations. Tone and pattern detection functions required by the applicable ITU or Bell standards are supported and dialling, call progress, and the telephone line interface are supported and controlled through the AT command set. The modem connects to the DTE (Data Terminal Equipment, such as a PC, industrial controller or telemetry outstation) via a serial interface (EIA RS232).

The module has 2 interface ports: Serial interface, RS 232 (9 pole sub-D) with hardware handshake control lines - and the telephone line interface. (6 pole RJ11 modular jack).

The built-in power supply for 12-48VDC, is provided with galvanic isolation.

The modems are made in industrial 108mm wide aluminium housing for DIN rail mounting.

VERSIONS/ORDERING CODE

Type

UCM Modem

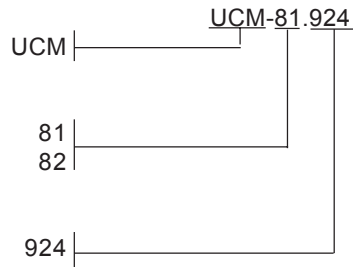

Modem Speed

V.32bis 14.400Baud
V.90 56.000 Baud

Power supply

12-48V DC

BLOCK DIAGRAM

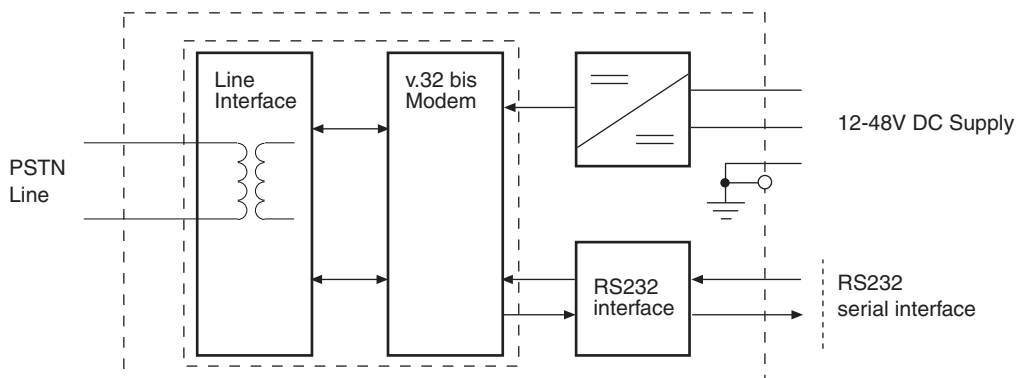

PSTN Modem
UCM-81/82**TECHNICAL DATA**

Signal level: RS232C/V24.

Connector: 9 pole sub-D, female.

Hardware handshake: DCD, DTR, DSR, RTS, CTS, RI

Baud Rate: 300, 600, 1200, 2400, 4800, 9600, 19200, 38400, 57600, 115200, 230400.

Format: 7, 8 bit (binary), 1 start bit.
Odd, even, No parity, 1, 2 stop bit (if 7 data bit, no parity).

Default setup: 9600bps, no parity, automatic format/speed sensing

Telephone line interface

Connector: 6 pole RJ11 type modular jack

Modem Speeds: K56flex, V.90, V.34, V.32bis, V.32, V.23, V22bis, V.22A/B, V.21, Bell 212A and 103

Data mode: Speed buffering at all line speeds up to 115.200bps supported.
XOFF/XON or RTS/CTS flow control supported.

Error correction: V.42 LAPM and MNP 2-4

Data compression: V.42 bis and MNP5 (MNP10 data throughput enhancement)

REN: Ring Equivalent Number <1

Modem control: Hayes compatible. AT command set.

Dial-up: DTMF or pulse dialling

Approvals: Pan European CTR21 standard.
Can be configured to support a wide range of national settings.

Indicators:

Rxd: Red, indicating receiving data activity.

Txd: Red, indicating transmitting data activity.

DCD: Red, carrier detect/modem connect.

DTR: Red, ready to transmit/receive data.

Power: Green.

Isolation

Power supply to electronics: 500 V.

Line interface: 1500 V.

Power supply:

Supply voltage: 12 - 48V DC (10,5-60,0V).
Reverse polarity protected.
Protective earth required

Current consumption:

<u>Supply voltage</u>	<u>Typical</u>	<u>Max.</u>
12V	115	140
24V	55	75
48V	30	49

- Ambient temperature:** -10 to +55 degrees C (+5% to +95% humidity).
- EMC:** EN 50081-1/EN50082-2.
- Climatic:**
Dry heat: IEC 68-2-2, Test Bd, Temp. +55°C, Duration 8h.
Cold: IEC 68-2-1, Test Ad, Temp. -10°C, Duration 8h.
Damp heat: IEC 68-2-3, Test Ca, Temp. 40°C, RH 95%, duration 8h.
- Mechanical:**
Vibration: IEC 68-2-6, Test Fc (sinusoidal), Freq.10-150Hz, Amp.4g, 5 sweeps in 3 orthogonal axes.

Shock: IEC 68-2-27 (half sine), Acc. 15g, Pulse time 11msec., 3 x 6 shocks.
- Protection:** IP20.
- Mounting:** 35 mm DIN-rail, EN50022.
- Terminals (power):** Max. 1.5 mm² wire.
- Housing:** Anodized aluminium with plastic ends. According to DIN 43880.
- Dimensions:** HxWxD: 80 (+ connectors) x108 x 62 mm.

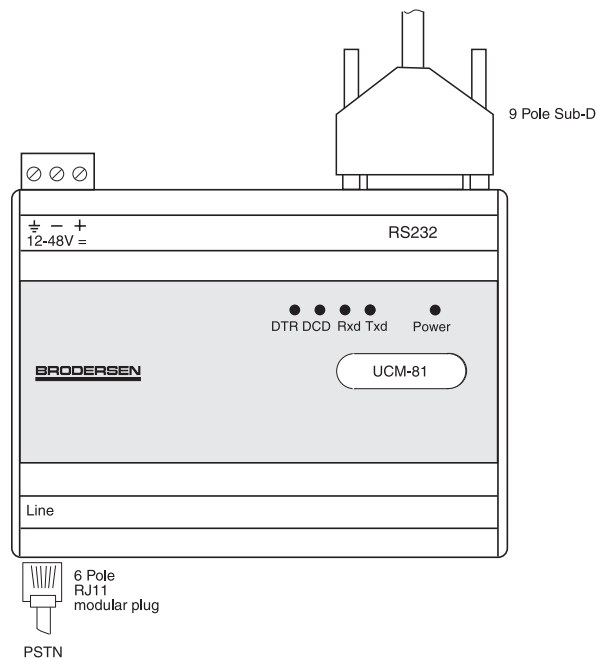
WIRING DIAGRAM

PSTN Modem
UCM-81/82**Telephone line interface (RJ11 modular jack - 6 pole)**

Pin no	Signal name	IO Type	Interface
1	-	-	Not used . No connection needed.
2	-	-	Not used . No connection needed
3	A	BI	Bi-directional phone line (A= TIP)
4	B	BI	Bi-directional phone line (B = RING)
5	-	-	Not used . No connection needed
6	-	-	Not used . No connection needed

RS232 serial interface (9 pole sub-D female)

Pin	Signal label	IO type	Interface
1	DCD	Out	Data Carrier Detect.
2	RXD	DCD	Receive Data. The interface uses the RX to send data received from the telco line to the DTE.
3	TXD	In	Transmit Data. The DTE uses the TX line to send data to the interface for transmission over the telco line.
4	DTR	In	Data Terminal Ready. Turned On when DTE is ready to transmit or receive data.
5	SG	Gnd	
6	DSR	Out	Data Set Ready. OFF (high) indicates that the DTE is to disregard all signals appearing on the interface
7	RTS	In	Request To Send. RTS is used to condition the interface for data transmission .
8	CTS	Out	Clear To Send. Indicates whether or not the interface (modem) is ready to transmit data. CTS is a response to DTR and RTS.
9	RI	Out	Ring indication.

Modem configuration / DTE commands

The modem is configured by AT commands when in command mode. Command mode is normally when no dial up sequence is executed and when connection to other modem is not established. A command is a line of characters sent from the DTE to the Modem via the serial interface. When setting up your modem you can use a PC with Terminal Software, such as Hyper Terminal supplied Microsoft Windows. A command line always starts with AT (except A/ and +++) followed by the specific command and terminated by a carriage return (Enter). When a command is followed by a "n" it mean that the command have several options, such as ATEn. When the modem receives a carriage return the command is executed.

You may use both upper case and lower case characters, but not both.

A command line starting with AT can be followed by many commands in sequence, except for the commands Z, D or A. The maximum number of characters in a command line is 39 including the A and T.

Up to four telephone numbers can be stored in the modem.

See the section "AT Command" for a list of the valid AT commands.

Default factory configuration profile:

ACTIVE PROFILE:

B0 E1 L1 M1 N0 Q0 T V1 W0 X4 Y0 &C1 &D2 &G0 &J0 &K3 &Q5 &R1 &S0 &T5 &X0 &Y0
S00:005 S01:000 S02:043 S03:013 S04:010 S05:008 S06:003 S07:050 S08:002 S09:006
S10:014 S11:095 S12:050 S18:000 S25:005 S26:001 S36:007 S38:020 S46:138 S48:007
S95:000

STORED PROFILE 0:

B0 E1 L1 M1 N0 Q0 T V1 W0 X4 Y0 &C1 &D2 &G0 &J0 &K3 &Q5 &R1 &S0 &T5 &X0
S00:005 S02:043 S06:003 S07:050 S08:002 S09:006 S10:014 S11:095 S12:050 S18:000
S36:007 S40:104 S41:195 S46:138 S95:000

STORED PROFILE 1:

B0 E1 L1 M1 N0 Q0 T V1 W0 X4 Y0 &C1 &D2 &G0 &J0 &K3 &Q5 &R1 &S0 &T5 &X0
S00:005 S02:043 S06:003 S07:050 S08:002 S09:006 S10:014 S11:095 S12:050 S18:000
S36:007 S40:168 S41:195 S46:138 S95:000

TELEPHONE NUMBERS:

0= 1=
2= 3=

OK

Special national settings

The modems are default configured to meet CTR-21 european requirements. But with the AT & GCI command, the modem can be changed to comply with other national settings and requirements. Please see the details in the AT command section in the UCM-81/82 manual under the command AT & GCI.

ACCESSORIES

UCC-565 Modem cable 9 pin D-sub male/female, 0,5m shielded.

UCC-567 Modem cable 9 pin D-sub male/female, 1,5m shielded.